



Nevada Terawatt Facility
Physics Department
College of Science
University of Nevada, Reno

2010 Science with High-Power Lasers and Pulsed Power August 3-6, 2010

Research at the Nevada Terawatt Facility

University of Nevada Reno

Joseph M. Kindel



Nevada Terawatt Facility
Physics Department
College of Science
University of Nevada, Reno

- Introduction
- NTF Z-pinch results of potential interest to Sandia
- Some new NTF diagnostics



Nevada Terawatt Facility
Physics Department
College of Science
University of Nevada, Reno

Facilities

Zebra	2 TW, 80 ns pulsed power Z-pinch
Leopard	50 TW, 350 fs short pulse laser or 1ns for long pulse
Cheetah	10 TW, 35 fs short pulse laser with high contrast ratio
Computer Cluster	86 nodes 18.6 TBytes



Nevada Terawatt Facility University of Nevada, Reno, NV



ZEBRA

2 TW Pulsed Power Generator

load chambers: 1 (Zebra)
flexible electrode configuration

Repetition rate:
up to 3 shot/day

Impedance: 1.9 ohm

Short current pulse:

Peak current: 1 MA
Rise time: 100 ns

Long current pulse:

Peak current: 0.6 MA
Rise time: 200 ns

LEOPARD

50 TW Laser (1057 nm)

target chambers: 1 (Phoenix)
1.6m DIA

beams: 1

Repetition rate:
up to 1 shot / hour

Laser pulse on target:

Energy: 15 J 25 J
Pulse width: 350 fs 1ns
Peak flux density: 10^{19} W/cm²
Contrast ratio: $>10^5$

Plasma diagnostics

Zebra load chamber

Optical:

Laser shadowgraphy, schlieren
Intensified CCD camera
Streak camera

X-ray:

X-ray pinhole camera
Gated x-ray imager
Crystal x-ray spectrograph
Gated x-ray spectrometer
PCDs, XRDs, bolometers

Particle:

Scintillator-photomultipliers
Faraday cups

In preparation:

UV laser probing
X-ray backlighting
X-ray streak camera

Phoenix target chamber for laser experiments

X-ray spectrometers
X-ray imaging, CCD camera
Faraday cups, B-dots
Magnetic spectrometer

Laser Diagnostics:

Energy, far field, near field, and
pulse duration

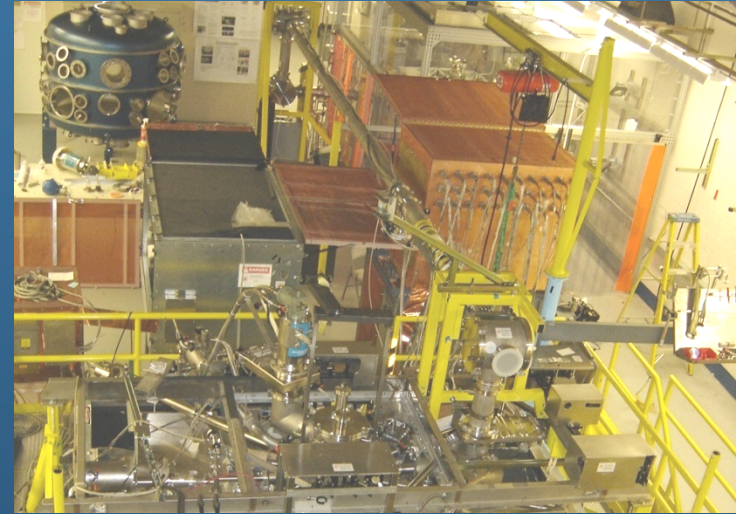

General Information

Facility POC	Dr. Joseph M. Kindel (jkindel@unr.edu)
Zebra POC	Dr. Radu Presura (presura@physics.unr.edu)
Laser POC	Dr. Piotr Wiewior (pwiewior@unr.edu)
External users	Up to 25%, by collaboration
User guide	See web site
Review cycle	Semiannual
Web site	http://www.ntf.unr.edu/



Nevada Terawatt Facility
Physics Department
College of Science
University of Nevada, Reno

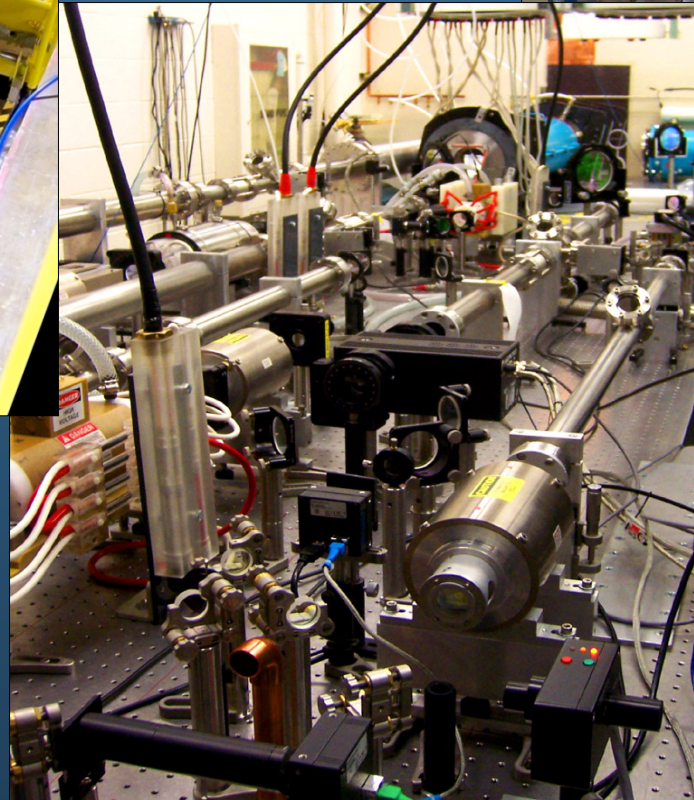
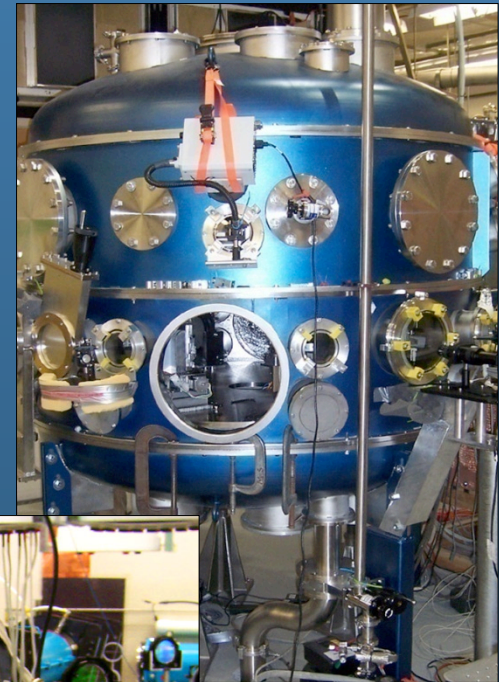
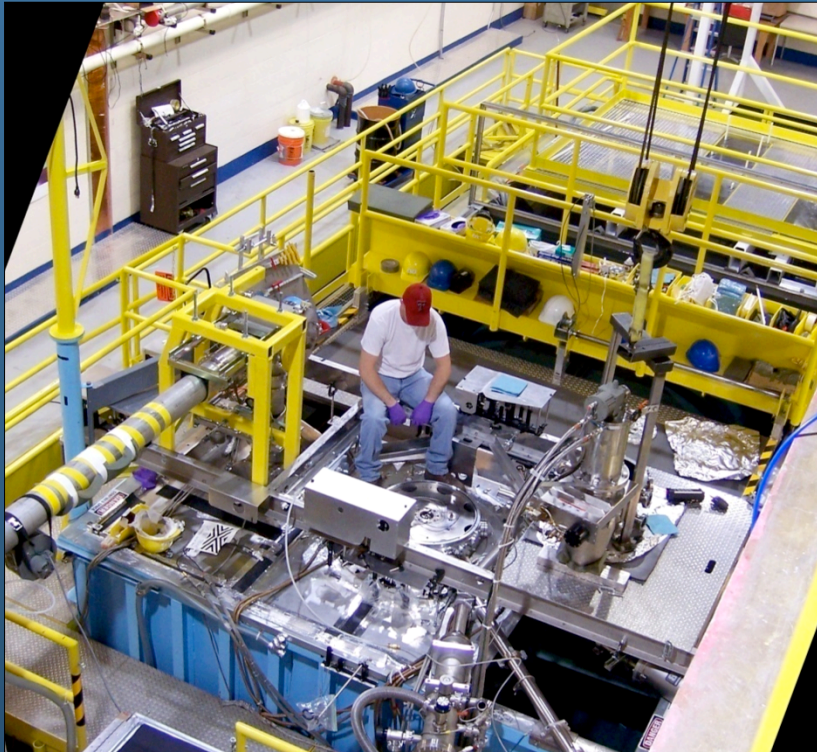

2009: 350 shots on Zebra



Nevada Terawatt Facility
Physics Department
College of Science
University of Nevada, Reno

Zebra current multiplier implementation(1.9MA)

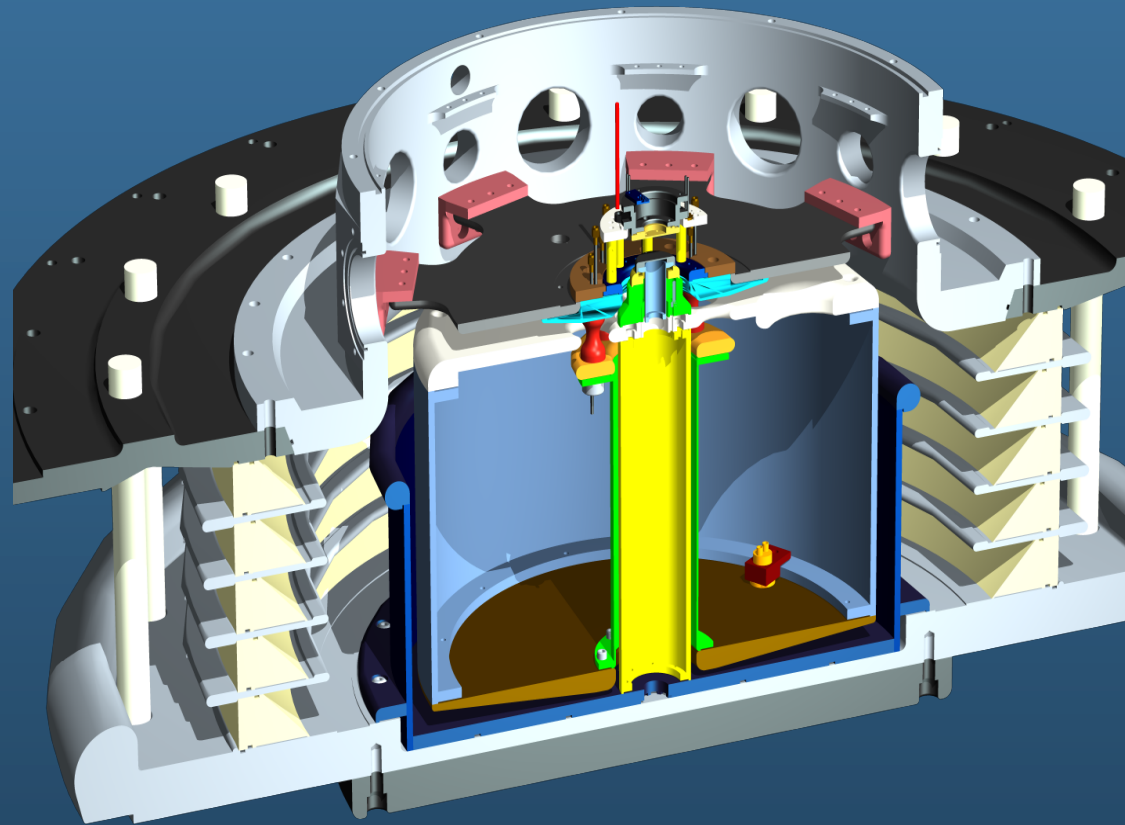

After successful testing of prototype of load current multiplier (LCM) (Sandia NL, Ecole Polytechnique and an NTF collaboration), the new permanent Zebra chamber setup modification was done. The under load LCM position insures an ease chamber operation. The modification allows to retrofit vacuum chamber to accommodate the standard (non LCM) configuration.

The improvement of UNR / NTF Zebra generator in 2007 –

2010

V.Kantsyrev* (UNR), A. Chuvatin (Ecole Polit.,France), L. Rudakov (Icarus Inc.), M. Cuneo (SNL), A.Astanovitskiy, R. Presura, W. Cline, A. Safronova, A. Esaulov, K. Williamson, I. Shrestha, G. Osborne, M. Weller, V. Shlyaptseva, B. LeGalloudec, V. Nalagala, S. Batic (UNR)

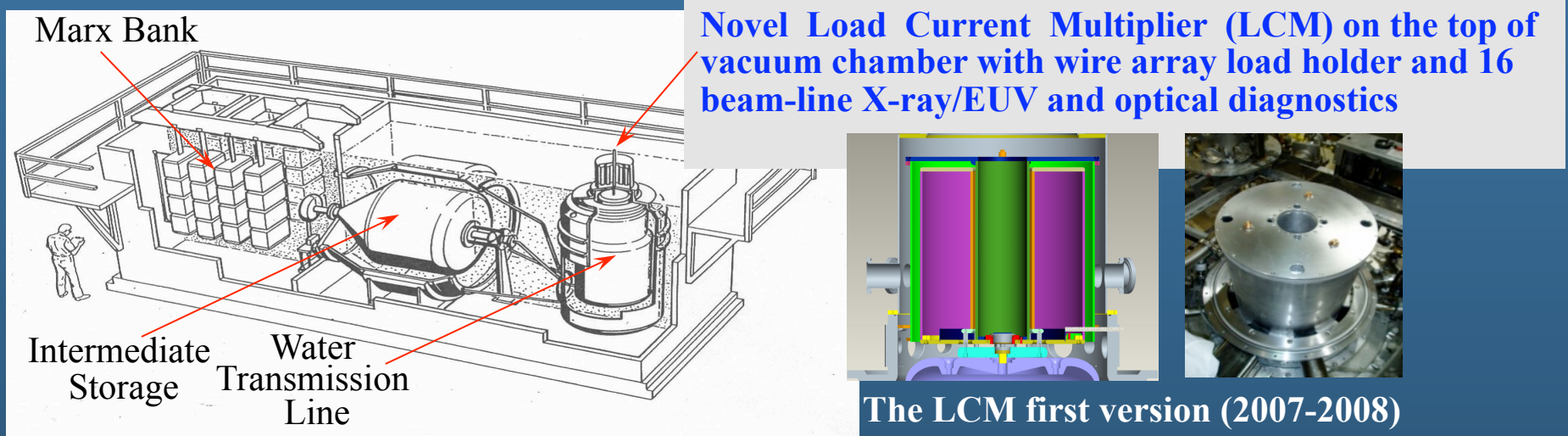

UNR/NTF Zebra in 2010: current 0.9 MA in standard mode and up to 1.7 MA (wire array) and 1.9 MA (short circuit) with Load Current Multiplier (LCM*); current rise-time 100-110 ns; impedance 1.9 Ω ; initial stored energy ~150 kJ

* A.S. Chuvatin, V. L. Kantsyrev, L.I. Rudakov *et al*, Physical Review, S.T. Accelerators and Beams, v. 13, pp. 010401-1÷8 (2010).

* PI in the SNL Grant # # 681371

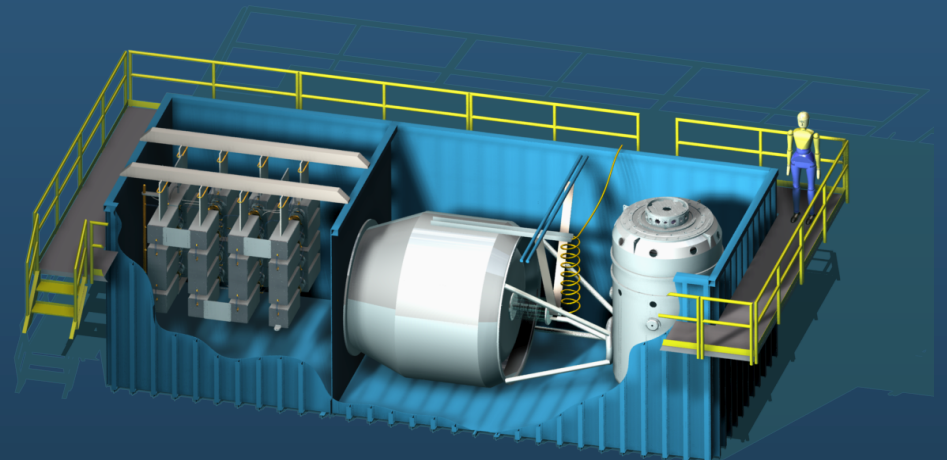

Main results of the LCM application on Zebra in 2008 - 2010

Load peak current range: 0.9 - 1.9 MA with short circuit load

0.9 - 1.7 MA with plasma generated loads

1. X-ray yields current scaling in experiments with compact planar wire arrays: total yield $E_T \sim I^{1.8}$, sub-keV peak power $P \sim I^{1.8}$ for single and double planar wire arrays*.
2. Participation with a LCM in SNL/UNR research on X-ray yields current scaling with planar wire array at multi-MA drive currents for a new compact multisource hohlraum configuration**.
3. Hard X-ray (> 10 keV) current scaling in experiments with compact planar and cylindrical wire arrays***: hard x-ray yield $E_{HXR} \sim I$.
4. Appearance of absorption x-ray spectra from compact cylindrical wire arrays and single planar wire arrays plasmas with rise peak current due to opacity effects****.

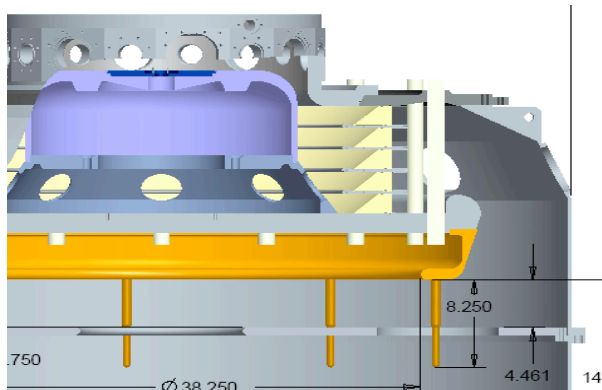

Conventional configuration of Zebra vacuum chamber and load holder

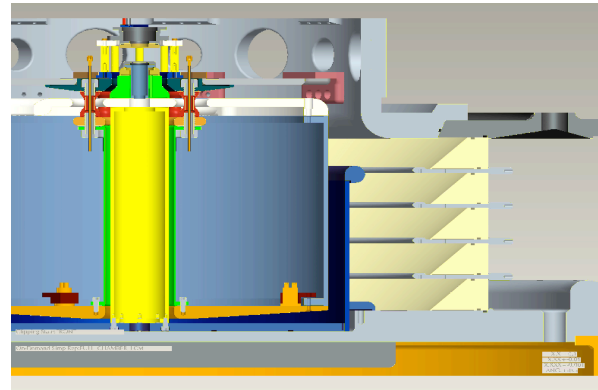

Second version of the LCM with load holder – integrated part of Zebra generator

*K. Williamson et al., AIP Conf. Proc. v. 1088, 141 (2009), and V. Kantsyrev et al, HEDP, v.5 , 115-123 (2009);

** B. Jones et al., Phys. Rev. Lett., v. 104, 125001 (2010); *** I. Shrestha et al., HEDP, v.6 , 113-120 (2010);

** * V. Kantsyrev et al, HEDP, v.5 , 115-123 (2009)



Magneto-Rayleigh-Taylor Instability

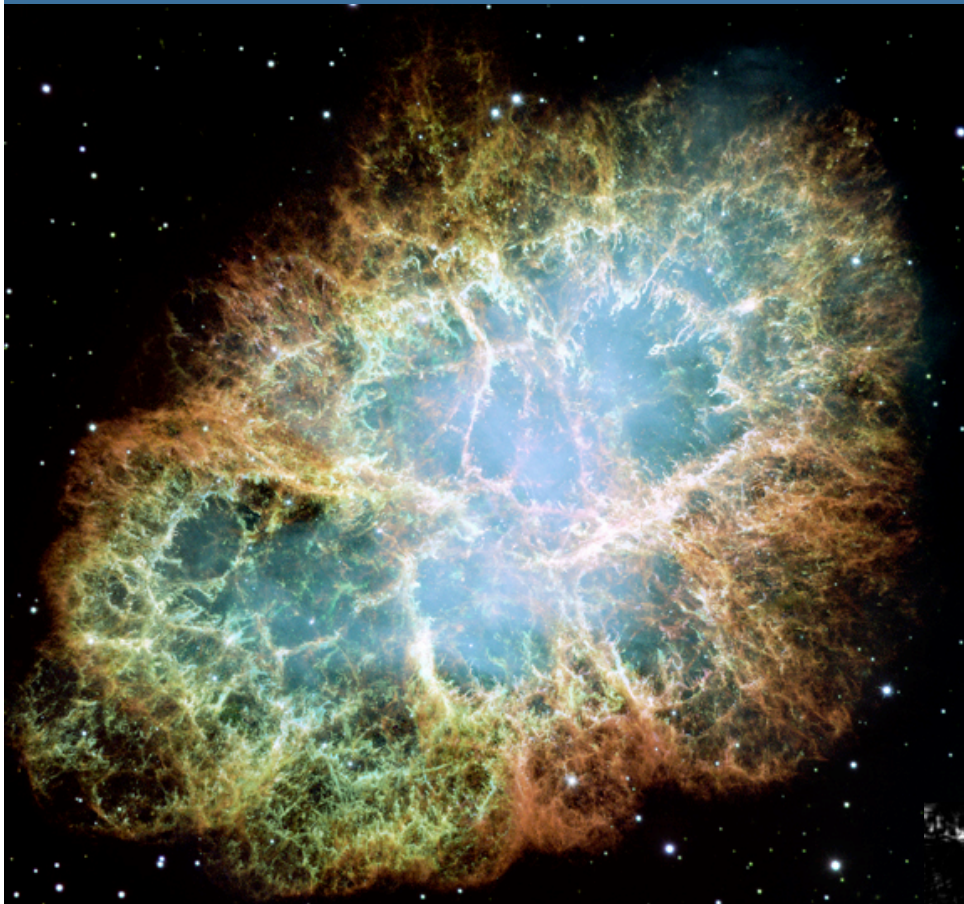

Crab Nebula (NASA/ESA/ASU/J.Hester & A.Loll)

C. Plechaty *et al.*, ApSS 322 (2009) 195

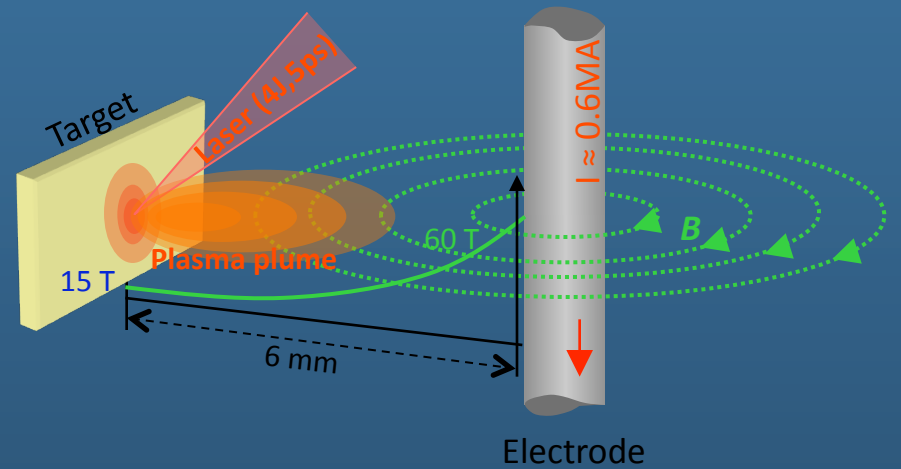

$T_0 + 9\text{ns}$

$T_0 + 14\text{ns}$

$T_0 + 21\text{ns}$

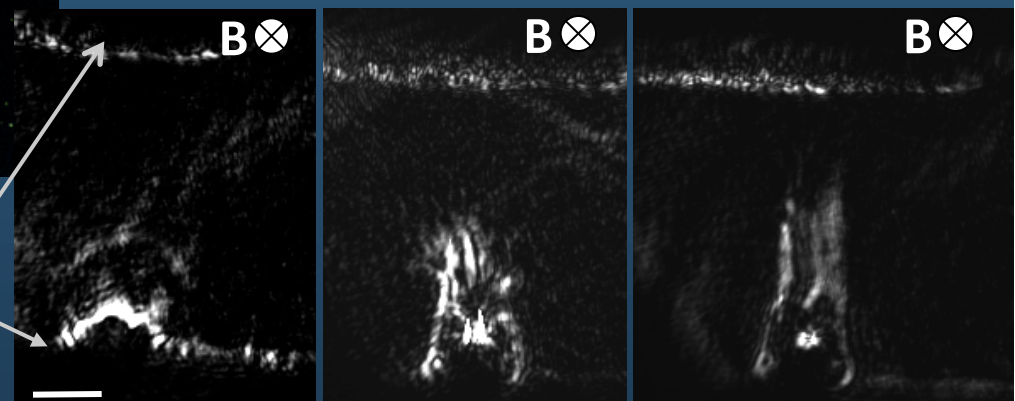



Nevada Terawatt Facility
Physics Department
College of Science
University of Nevada, Reno

Flute-like structures form at plasma plume front as it decelerates across the magnetic field

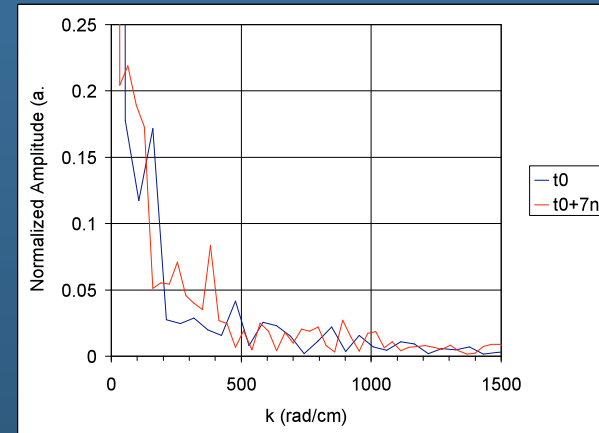
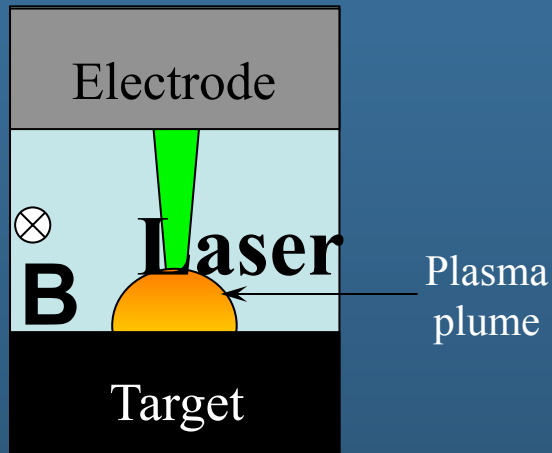

experimental
Fourier spectrum

excitation of both large scale structures (zonal flows) and short scale (Kolmogorov type) turbulence

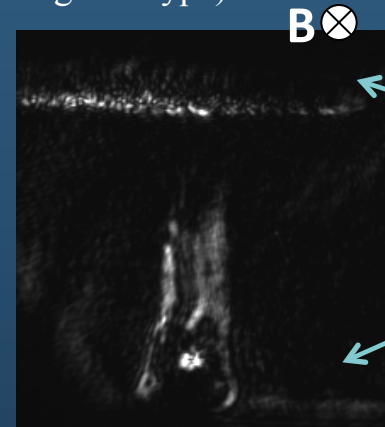
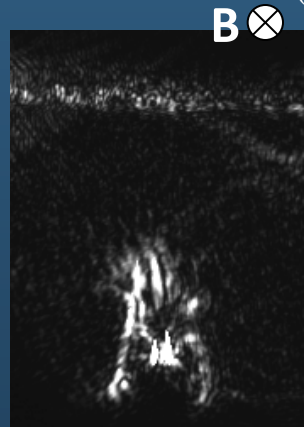
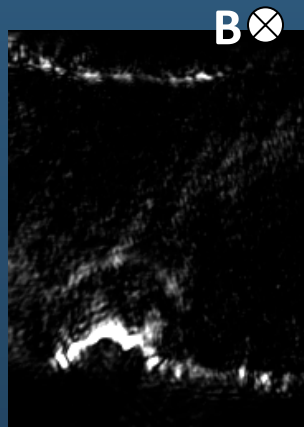

Electrode

Target

1m

$T_0 + 2ns$

$T_0 + 9ns$

$T_0 + 14ns$

$T_0 + 21ns$

Schlieren images of the plasma plume, as it propagates through the external magnetic field



Nevada Terawatt Facility
Physics Department
College of Science
University of Nevada, Reno

New Diagnostics

- UV laser
- X-ray backlighter
- progress on absorption spectroscopy
- proton deflectometry



Nevada Terawatt Facility **Study of the microstructure of the Z-pinch (Ivanov)**

College of Science

University of Nevada, Reno

The radiated x-ray energy of z-pinches can exceed by 30-50% the implosion kinetic energy and Spitzer resistive heating*. New high-resolution UV probing diagnostics should help to identify mechanisms of z-pinch heating.

UV shadowgraphy at 266 nm shows details hidden in dense plasma during implosion and stagnation phases

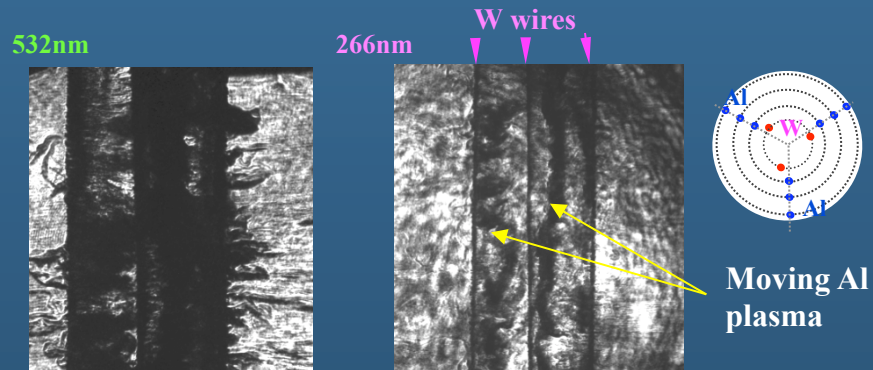

NEXT STEP

High-resolution UV probing will be developed

1. Two-frame shadowgraphy;
2. Interferometry;
3. Faraday rotation diagnostic.

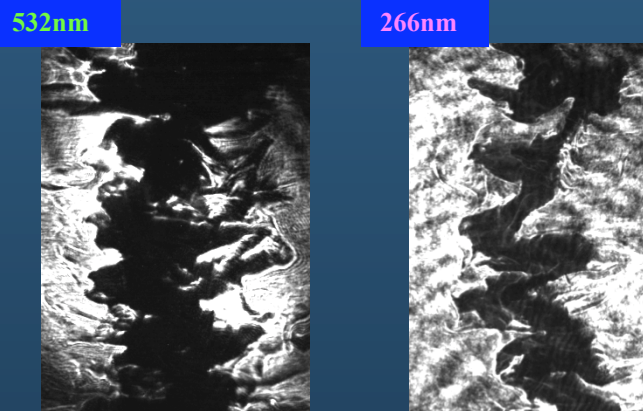

With a resolution $\sim 2-3 \mu\text{m}$, plasma turbulence, magnetic bubbles, and other small-scaled features will be observable in the z-pinch.

Mechanisms of “enhanced” plasma heating can be identified.

A structure of the Z-pinch is seen at 266 nm

High-Resolution Images of the Z-pinches

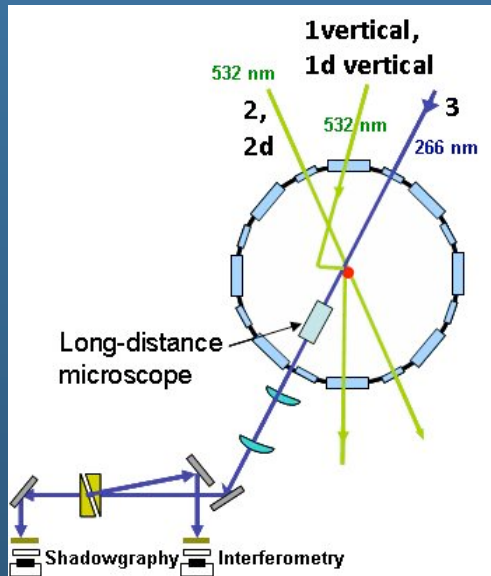

A spatial resolution is $5\mu\text{m}$

Implosion stage

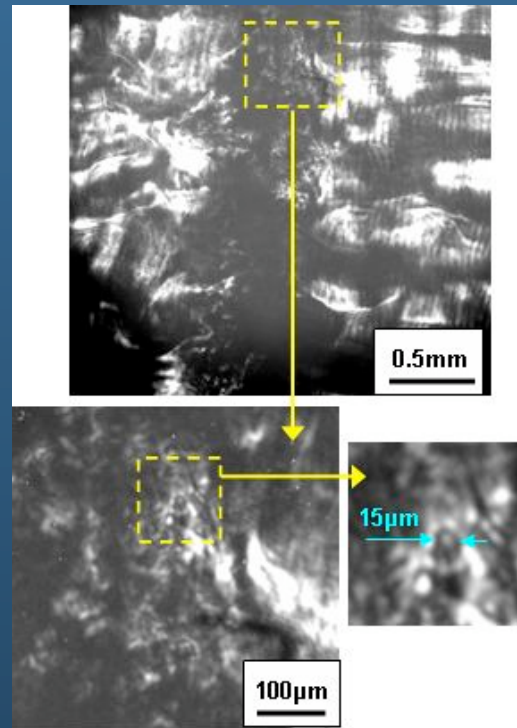

#2183. Al 1 cylindrical, $\text{\O}12\text{mm}$

Stagnated Z-pinch

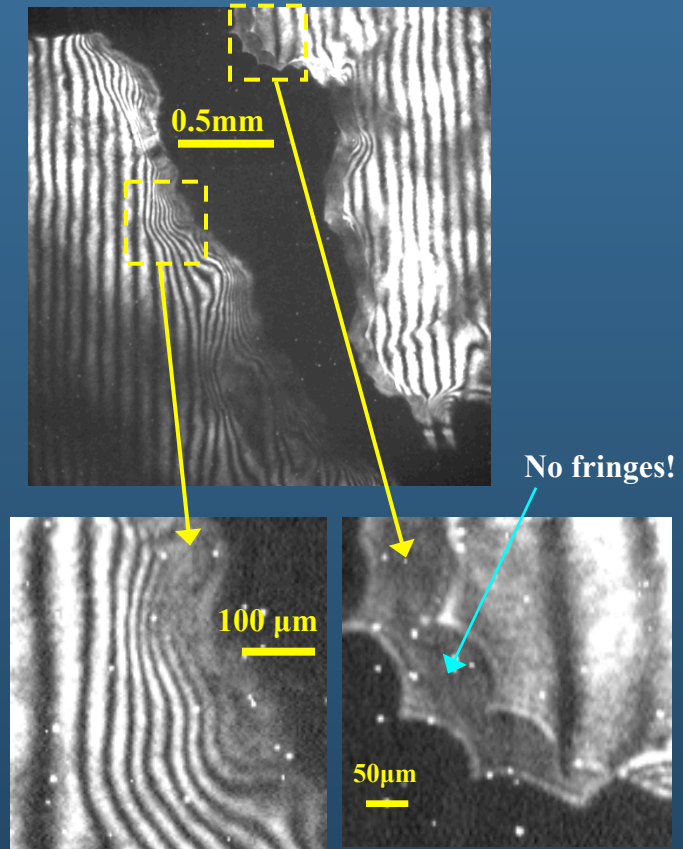

#2189. Al 15-wire star

Z-pinch structure is seen at 266 nm

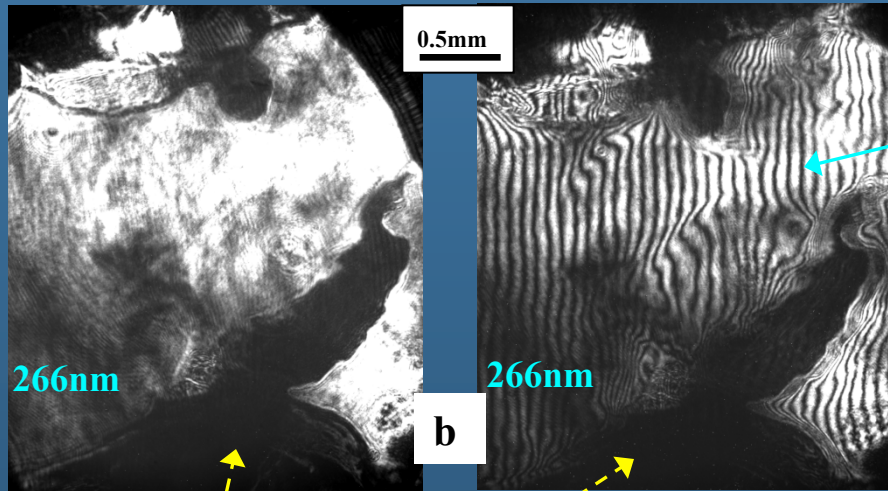

Discontinuity is seen in the plasma column of the stagnated Z-pinch

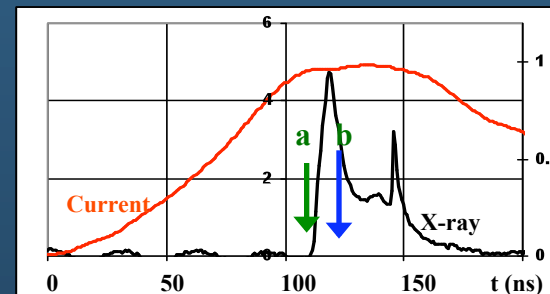
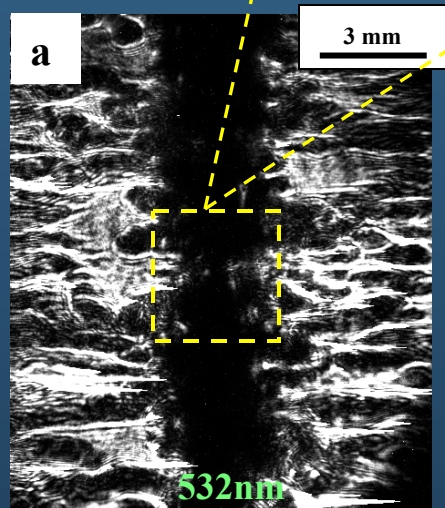

#2210. Al 15-wire star



Nevada Terawatt Facility

College of Science
University of Nevada, Reno

Development of x-ray absorption spectroscopy for wire-array plasmas

V. Ivanov, P. Hakel, R.C. Mancini (UNR),
A. Shevelko (BYU), 3 grad. students

Synthetic transmission spectra of Al plasma show K-shell absorption lines

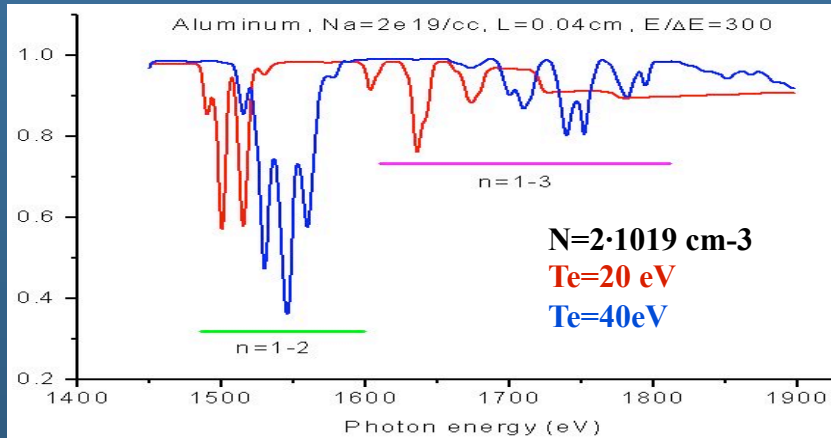

Motivation:

- Study of wire-array Z-pinches at the non-radiative stage
- Use Leopard laser as a driver for broadband x-ray backlighter
- Intensity distribution of backlighter has to be characterized
- Blocking the bright radiation of the wire-array pinch is a critical issue in the experiment:
 Zebra generates Erad >10 kJ
 Leopard $E_{1\mu m}=10 \text{ J}$

Sm and Ge plasmas are sources of broadband x-ray radiation (experiments in the Phoenix vacuum chamber)

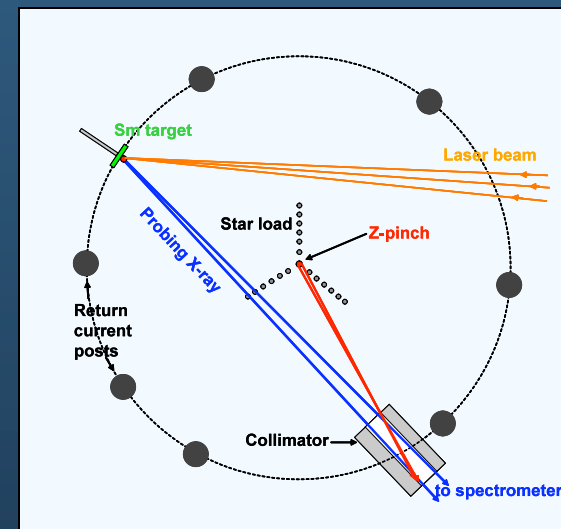
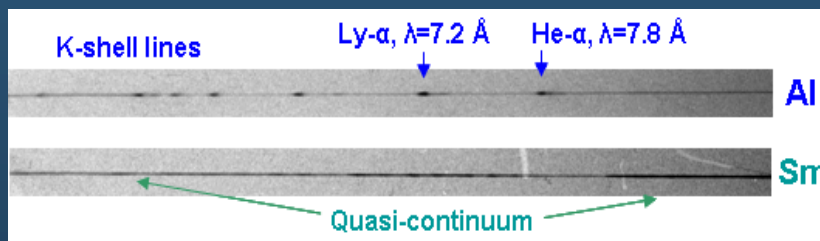

Green light shadowgram and x-ray absorption spectroscopy of the ablation stage of star wire arrays



#2204

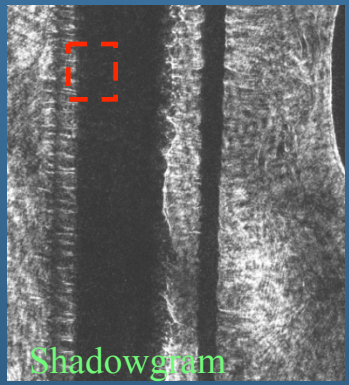

Radiation from pinch was blocked by collimators. Shadowgraphy shows plasma conditions during the X-ray backlighting.

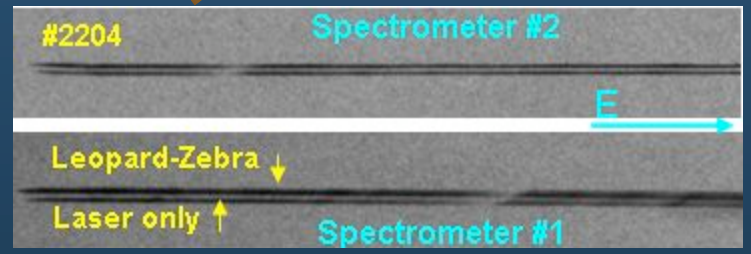
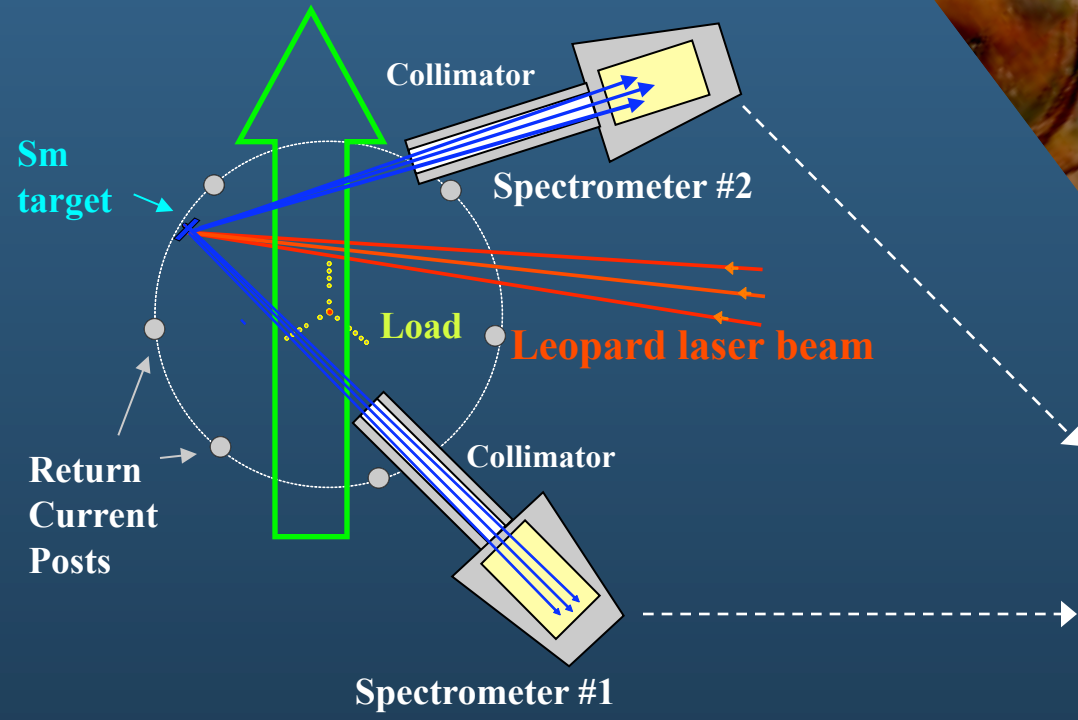
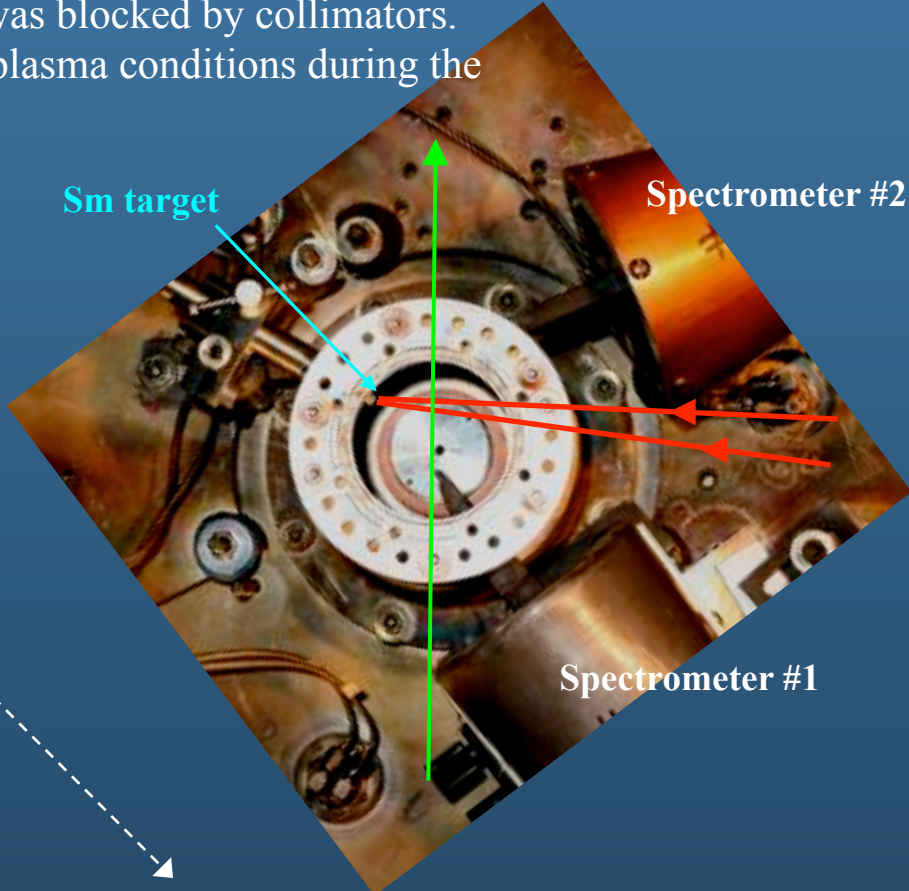

Initial results are encouraging: line absorption is observed in wire-array plasma



Small shot-to-shot variations



Absorption lines are seen in wire-array plasma

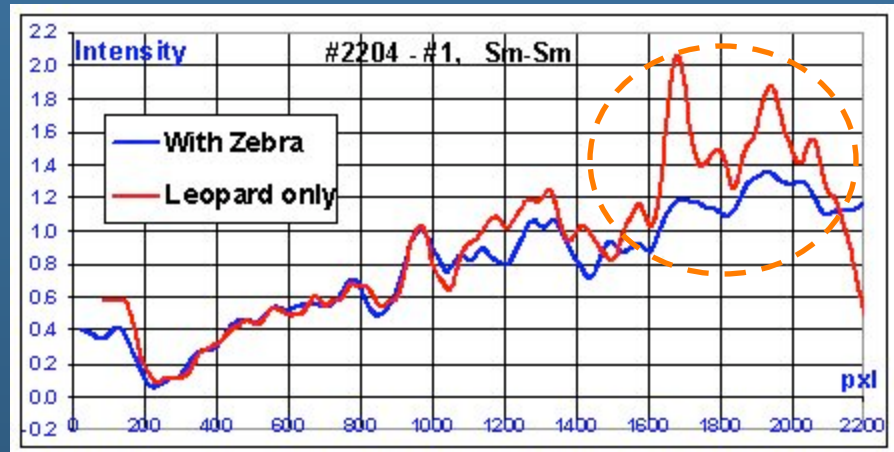

Modeling of K-shell Al transmission spectra*

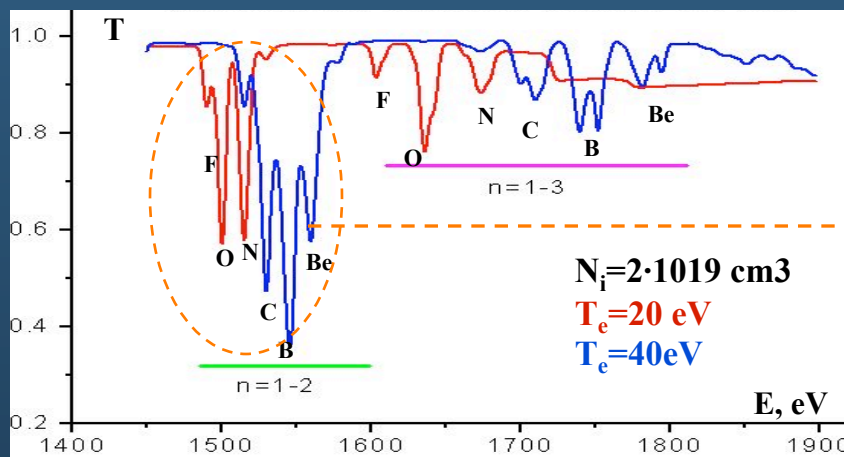

Average transmission for 3 shots

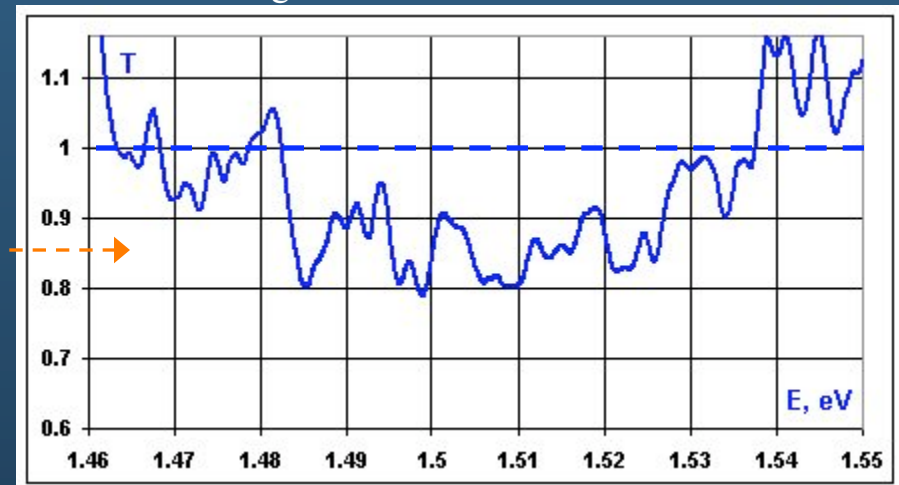

* P. Hakel, R. C. Mancini, T. Durmaz, simulations with PrismSPECT and AtoKin

Assessment of Proton Deflectometry for Exploding Wire Experiments

- Magnetic field structure in exploding wire experiments is complex and is difficult to measure with conventional methods.
- Proton deflectometry has the potential to recover details of the B-field vital to the accurate interpretation and benchmarking MHD codes.

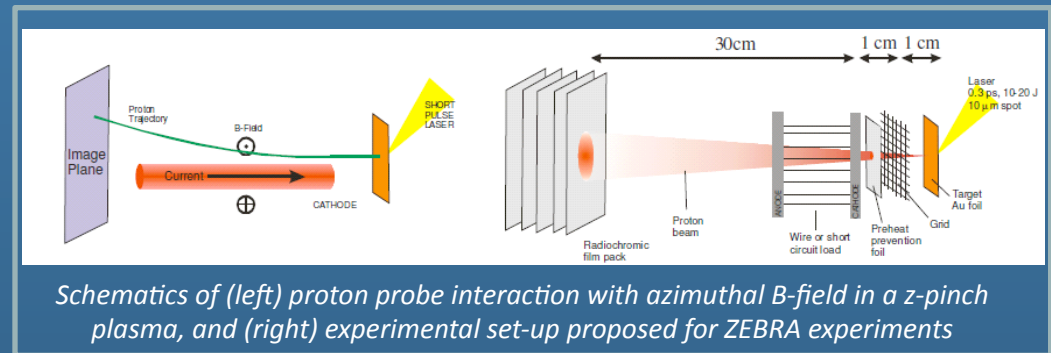

- The UC San Diego-led project utilizes both the 50 TW leopard laser system (10J, 0.3ps) and the 1MA ZEBRA pulsed power driver at NTF, and is the first application of proton deflectometry to pulsed power experiments.

- First experimental series demonstrated focussed laser intensities of 5×10^{19} W/cm² and proton spectra up to 8 MeV
- Proton beam showed good reproducibility and low divergence

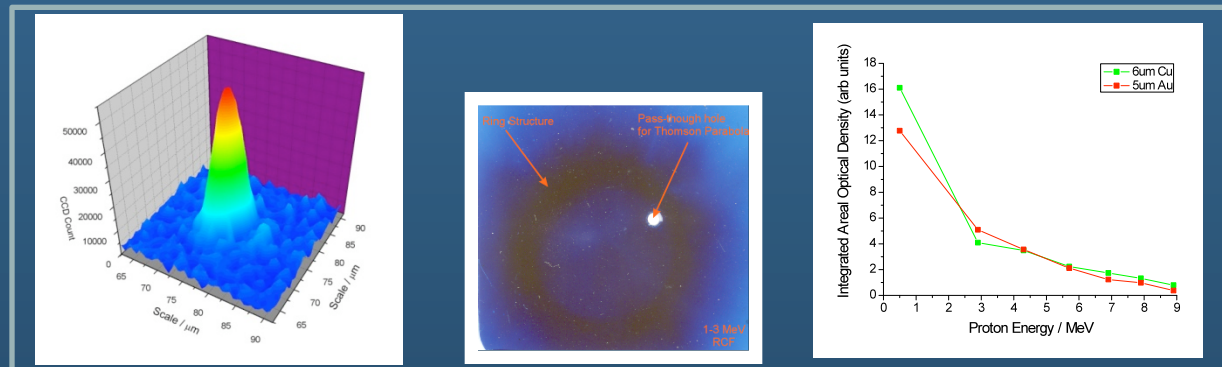

Measured Laser beam profile, RCF film showing 1-3 MeV proton beam, and proton spectrum

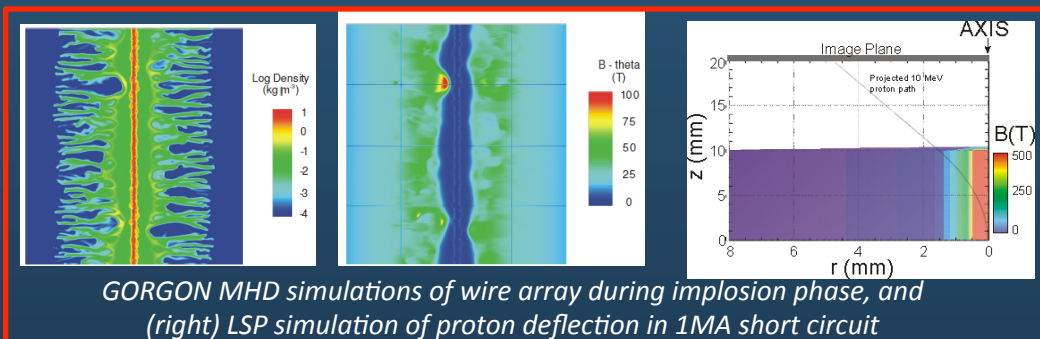

- Simulations combine MHD and PIC codes
- 3D MHD code GORGON is well benchmarked against exploding wire experiments, and provides the density and electromagnetic field maps and LSP calculates the proton deflection, based on GORGON output, to compare to experiments



Nevada Terawatt Facility
Physics Department
College of Science
University of Nevada, Reno

Summary

- At low cost increased Zebra z-pinch current to 1.9 MA for short circuit
- Laser-Plasma Experiments to isolate Magnetic Rayleigh-Taylor instability
- XUV diagnostic at 266 nm reveals phenomena at pinch stagnation
- New x-ray backlighting and absorption spectroscopy to diagnose Zebra z- pinch
- Began work with UCSD on Proton Deflectometry